

Project Information

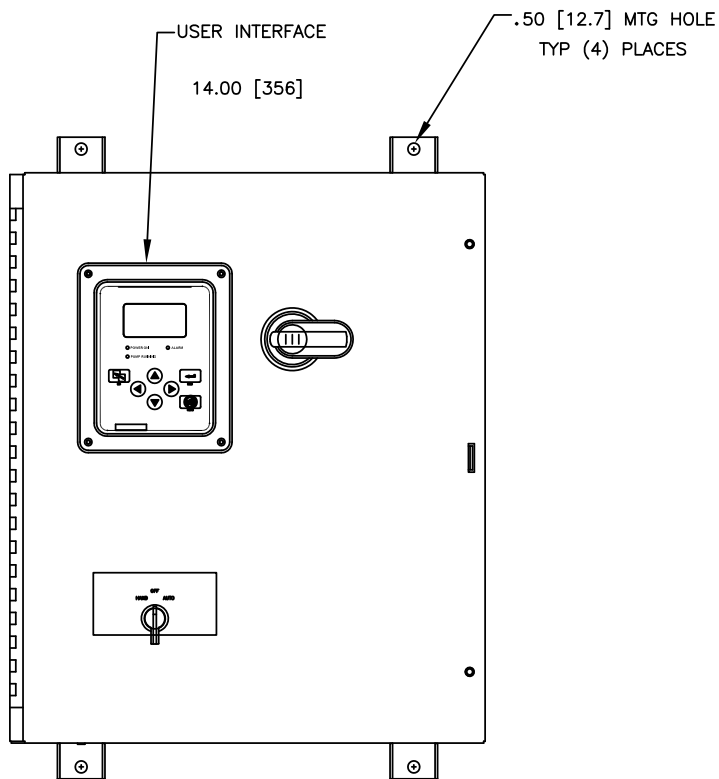

(DRAWINGS INCLUDED IN THIS PACKAGE ARE FOR STANDARD CONTROLLERS. ACTUAL "AS BUILT" DRAWINGS MAY DIFFER FROM THOSE SEEN HERE).

Firetrol, Inc.

3412 Apex Peakway
Apex, North Carolina 27502
P 919 460 5200
F 919 460 5250
www.firetrol.com

While every precaution has been taken to ensure accuracy and completeness herein, Firetrol, Inc. assumes no responsibility, and disclaims all liability, for damages resulting from use of this information or for any errors or omissions. Specifications and drawings are subject to change without notice. ©2019 Firetrol, Inc., All Rights Reserved.

Firetrol JockeyXG Pump Controller

FTA556E – Wye Delta Open Transition Starting Specifications

1.0 Main Fire Pump Controller

The auxiliary jockey pump controller, if required and specified on the plans and specifications, shall be factory assembled, wired, and tested and specifically designed for this type of service. This controller shall be of the same manufacturer as the main fire pump controller.

1.1 Standards, Listings & Approvals

The controller shall conform to all the requirements of the latest editions of: NFPA 70, *National Electrical Code*.

The controller shall be listed by:

Underwriters Laboratories, Inc., in accordance with UL508A, *Standard for Industrial Controls*
Canadian Standards Association CSA-C22.2, *Standard for Industrial Control Equipment* (cUL)

1.2 Enclosure

The controller components shall be housed in a NEMA Type 2 (IEC IP22) painted steel, wall mounted enclosure (UL50E Construction).

1.3 Withstand Ratings (Short Circuit Current Ratings w/Circuit Breaker)

The jockey shall have standard short circuit current ratings of:

65kA @ 480 Volts Max. (3-Phase)

14kA @ 600 Volts (3-Phase)

1.4 Construction

The jockey pump controller shall be Wye-Delta Open Transition starting. The controller shall incorporate a circuit breaker and horsepower rated motor starter, control circuit transformer with 24VAC secondary and 200-600V multi-tap primary, main disconnect switch, HAND-OFF-AUTOMATIC selector switch and a 0-300 psi (0-20.7 bar) stainless steel solid state pressure transducer.

1.5 Operator Interface

The fire pump controller shall feature an operator interface with user keypad. The interface shall monitor and display motor operating conditions, including all alarms, events, and pressure conditions. All alarms, events, and pressure conditions shall be displayed with a time and date stamp. The display shall be a 128x64 Backlit LCD capable of customized graphics. The display and interface shall be NEMA rated for Type 2, 3R, 4, 4X, and 12 protection and shall be fully accessible without opening the controller door. The display and user interface shall utilize multiple levels of password protection for system security. A minimum of 3 password levels shall be provided.

1.6 Digital Status/Alarm Messages

The digital display shall indicate text messages for the status and alarm conditions of:

- Pump Running
- Low System Pressure
- Automatic Start
- Main Switch Position
- Sequential Start Time
- Pump Restart Timer
- System Overpressure
- User Selectable #2¹
- Minimum Run Time
- Fail to Start
- User Selectable #1¹

¹User may choose from the following to be shown on main display (stop pressure setting, start pressure setting, cycles/period, cycles/month, cycles/day, cycles/hour, total cycle count, pump total run time)

The Sequential Start Timer, Minimum Run Timer/Off Delay Timer and Pump Restart Timer shall be displayed as numeric values reflecting the value of the remaining time.

1.7 LED Visual Indicators

LED indicators, visible with the door closed, shall indicate:

- Power ON
- Alarm
- Pump Running

1.8 Data Logging

The digital display shall monitor the system and log the following data:

- Motor Calls/Starts
- Total Controller Pwr On Time
- Min/Max System Pressure
- Cycle Counts
- Pump Total Run Time
- Pump Last Run Time
- Last Pump Start
- Last Phase Fail/Reverse

1.9 Event Recording

Memory - The controller shall record all operational and alarm events to system memory. All events shall be time and date stamped and include an index number. The system memory shall have the capability of storing 3000 events and allow the user access to the event log via the user interface. The user shall have the ability to scroll through the stored messages in groups of 1 or 10.

2.0 Serial Communications

The controller shall feature a RS485 serial communications port for use with 2 or 4 wire Modbus RTU communications.

2.1 Solid State Pressure Transducer

The controller shall be supplied with a solid state pressure transducer with a range of 0-300 psi (0-20.7 bar) ±1 psi. The solid state pressure switch shall be used for both display of the system pressure and control of the fire pump controller. Systems using analog pressure devices or mercury switches for operational control will not be accepted.

The START, STOP and SYSTEM PRESSURE shall be digitally displayed and adjustable through the user interface. The pressure transducer shall be mounted inside the controller to prevent accidental damage. The pressure transducer shall be directly pipe mounted to a bulkhead pipe coupling without any other supporting members. Field connections shall be made externally at the controller coupling to prevent distortion of the pressure switch element and mechanism.

2.2 Seismic Certification

The controller shall be certified to meet or exceed the requirements of the 2012 International Building Code and the 2013 California Building Code for Importance Factor 1.5 Electrical Equipment for Sds equal to 1.88 or less severe seismic regions. Qualifications shall be based upon successful tri-axial shake-table testing in accordance with ICC-ES AC-156. Certification without testing shall be unacceptable. Controller shall be clearly labeled as rated for installation in seismic areas and a Certificate of Conformance shall be provided with the controller.

NOTE: Not available on Model FTA1500 Controllers

2.3 Controller Operation

A digitally set On Delay (Sequential Start) timer shall be provided as standard. Upon a call to start, the user interface shall display a message indicating the remaining time value of the On Delay timer.

The controller shall include a Minimum Run Timer to allow the motor to run for a set period of timer after starting. The timer shall be programmable through the user interface. A pump restart delay timer shall be provided to allow the residual voltage of the motor to decay prior to restarting the motor and to prevent severe short cycling of the motor. The timer shall be programmable through the user interface.

A Lamp Test feature shall be included. The user interface shall also have the ability to display the status of the system inputs and outputs.

An Audible Test feature shall be included to test the operation of the audible alarm device (if supplied).

The disconnect switch shall be mechanically interlocked so that the enclosure door cannot be opened with the handle in the ON position except by a hidden tool operated defeater mechanism. The disconnect switch shall be capable of being padlocked in the OFF position for installation and maintenance safety.

2.4 Manufacturer

The controller shall be a Firetrol brand.

Jockey_{XG} Pump Controllers - Wye-Delta Open Transition Starting



Description—Firetrol® FTA556E XG Jockey Pump Controllers are intended for use with fire pump systems. They are used for pressure maintenance in fire pump installations to prevent unnecessary operation of the main fire pump.

Approvals—Firetrol jockey pump controllers are listed by Underwriters’ Laboratories, Inc., in accordance with UL508A, *Standard for Industrial Controls*, and CSA, *Standard for Industrial Control Equipment*. They are built to meet or exceed the requirements of the approving authorities as well as NEMA and the latest edition NFPA 70, *National Electrical Code*.

Standard Features—The following are included as standard with each controller:

- NEMA Type 2 (IEC IP22) Painted Steel Enclosure
- Circuit Breaker
- Horsepower rated motor starters
- Suitable for use as service equipment
- HAND-OFF-AUTO selector switch
- Minimum run timer
- On-Delay timer
- Pump Restart Timer

- Transition Timer
- Control circuit transformer with 24VAC secondary
- 0-300 psi (0-20.7 bar) stainless steel solid state pressure transducer
- Overpressure indication
- Low Pressure indication
- Failed to start indication
- Main switch not in “Auto” alarm
- Pressure recording
- Event log (3000 events stored in controller memory)
- Data log (including cycle counter)
- Door mounted display/user interface featuring a 128 x 64 pixel backlit LCD Graphical Display, Membrane Type User Controller Push-buttons and LED indication for:
 - Power ON
 - Pump Running
 - Alarm
- 2 lines of user selectable display information

NOTE: FTA556E XG Jockey Pump Controllers are available as standard in the voltage/horsepower combinations shown below and with the options shown on the reverse side. For other combinations and options, please consult your Firetrol representative or the factory.

	VOLTAGE 3-PHASE	MAX HP	Short Circuit
	(50/60 Hertz)		Current
	Rating		
-H	200 - 208V	25	65kA
-A	220 - 240V	30	65kA
-F	380 - 415V	40	65kA
-B	440 - 480V	50	65kA
-C	550 - 600V	50	25kA

NOTE: Firetrol Brand Jockey Pump controllers DO NOT CONTAIN MERCURY filled pressure switches.

Product Description - Options & Modifications

SPECIAL ENCLOSURES

- E Enclosure, NEMA Type 4 (IP66), Painted Steel
- F Enclosure, NEMA Type 4X (IP66), #304 Stainless Steel, Brushed Finish
- FD Enclosure, NEMA Type 4X (IP66), #316 Stainless Steel, Brushed Finish
- FDB Enclosure, NEMA Type 4X (IP66), #316 Stainless Steel, 12 Gauge, Seam-Welded, Brushed Finish
- FDP Enclosure, NEMA Type 4X (IP66), #316 Stainless Steel, Painted Finish
- FXP Enclosure, NEMA Type 4X (IP66), #304 Stainless Steel, Painted Finish
- G Enclosure, NEMA Type 12 (IP54), Painted Steel
- T Enclosure, NEMA Type 3R (IP24), Painted Steel

HIGHER SHORT CIRCUIT CURRENT RATING

(See selection data sheet)

Fusible Disconnect Switch with Fuses (200kA)

ANTI-CONDENSATION SPACE HEATERS¹

- H Space Heater, 120V Externally Powered with Circuit Breaker
- J Space Heater, 120V Externally Powered with Circuit Breaker and Thermostat
- K Space Heater, 120V Externally Powered with Circuit Breaker and Humidistat
- L Space Heater, 240V Externally Powered with Circuit Breaker
- M Space Heater, 240V Externally Powered with Circuit Breaker and Thermostat
- N Space Heater, 240V Externally Powered with Circuit Breaker and Humidistat

¹ Power source supplied by others

PRESSURE TRANSDUCERS

- B Wetted Parts Including Pressure Sensor, 600 PSI (42 Bar), Fresh Water
- C Wetted Parts Including Pressure Sensor, 300 PSI (21 Bar), Sea Water
- D Wetted Parts Including Pressure Sensor, 600 PSI (42 Bar), Sea Water

MISCELLANEOUS

- AC Alarm Output Contacts, Pump Operating (2 Sets)
- AG Alarm, Audible/Visible, Reservoir Low
- AM Alarm Output Contacts, Fail To Start
- AST Input Terminals, Automatic Start
- AW Alarm Output Contacts, Reservoir Low (Requires option -AG)
- BW Alarm Output Contacts, Phase Failure/Phase Reversal
- BY Alarm Output Contacts, Pump Overload
- CPL Alarm Output Contacts, Overpressure
- EF Alarm Output Contacts, Main Switch Not In Auto (1 Set)
- HV Alarm, Audible
- IEC Marking, CE With External Wet Parts
- IECI Marking, CE With Internal Wet Parts
- KH Alarm Output Contacts, Common Alarm
- NZ Input Terminals, Shutdown Interlock
- OSP Marking, OSHPD Seismic Certification (State of California)(Requires option -SEI)
- PE Alarm Output Contacts, Low System Pressure (Pump On Demand)
- S Tropicalization
- SEI Marking, Seismic Certified
- ZPA Scheduled Service Message
- ZPJ Data Port, Serial Modbus RTU Over 2-Wire or 4-Wire RS485

*Export Packaging available for additional cost

NOTE: For requirements not listed here, please contact your Firetrol representative or the factory.

Firetrol, Inc.

3412 Apex Peakway
Apex, North Carolina 27502
P +1 919 460 5200
F +1 919 460 5250
www.firetrol.com

While every precaution has been taken to ensure accuracy and completeness herein, Firetrol, Inc. assumes no responsibility, and disclaims all liability, for damages resulting from use of this information or for any errors or omissions. Specifications and drawings are subject to change without notice. ©2019 Firetrol, Inc., All Rights Reserved.

Publication PD556E-01 Rev. D

Jockey_{xG} Pump Controllers - Wye-Delta Open Transition Starting

FTA556E JOCKEY_{xG} PUMP CONTROLLERS - WYE-DELTA OPEN TRANSITION

FTA556E-A A - (Example: FTA556E-AA015B-T-BY)

FTA NUMBER
FTA556E

TIMER OPTION
-A With Programmable
Running Period Timer

MOTOR CURRENT PROTECTION
-A Circuit Breaker
Suitable for Use as Service Equipment
Short Circuit Current Rating
200-480V - 65kA
550-600V - 14kA
-F Fusible Disconnect Switch w/ Fuses
Suitable for Use as Service Equipment
Short Circuit Current Rating
200-600V - 100kA (3-Phase)

HORSEPOWER (KW)
014 - 1/4 HP (.18) 004 - 4 HP (3)
013 - 1/3 HP (.23) 005 - 5 HP (3.7)
012 - 1/2 HP (.37) 006 - 5 1/2 HP (4)
034 - 3/4 HP (.56) 007 - 7 1/2 HP (5.5)
001 - 1 HP (.75) 010 - 10 HP (7.5)
011 - 1 1/2 HP (1.1) 015 - 15 HP (11)
002 - 2 HP (1.5) 020 - 20 HP (15)
003 - 3 HP (2.2) 025 - 25 HP (19)
 030 - 30 HP (22)
 040 - 40 HP (29)
 050 - 50 HP (37)

(See Voltage Selection for Maximum
HP/Voltage Combinations)

OPTIONS & MODIFICATIONS
(See other side)

VOLTAGE 3-PHASE (50/60 Hertz)	MAX HP
-H 200 - 208V	25
-A 220 - 240V	30
-F 380 - 415V	40
-B 440 - 480V	50
-C 550 - 600V	50

NOTE: For requirements not listed here
please contact a Firetrol represen-
tative or the factory.

Model Number Selection Guide - Options & Modifications

SPECIAL ENCLOSURES

- E Enclosure, NEMA Type 4 (IP66), Painted Steel
- F Enclosure, NEMA Type 4X (IP66), #304 Stainless Steel, Brushed Finish
- FD Enclosure, NEMA Type 4X (IP66), #316 Stainless Steel, Brushed Finish
- FDB Enclosure, NEMA Type 4X (IP66), #316 Stainless Steel, 12 Gauge, Seam-Welded, Brushed Finish
- FDP Enclosure, NEMA Type 4X (IP66), #316 Stainless Steel, Painted Finish
- FXP Enclosure, NEMA Type 4X (IP66), #304 Stainless Steel, Painted Finish
- G Enclosure, NEMA Type 12 (IP54), Painted Steel
- T Enclosure, NEMA Type 3R (IP24), Painted Steel

HIGHER SHORT CIRCUIT CURRENT RATING

(See selection data sheet)

Fusible Disconnect Switch with Fuses (200kA)

ANTI-CONDENSATION SPACE HEATERS¹

- H Space Heater, 120V Externally Powered with Circuit Breaker
- J Space Heater, 120V Externally Powered with Circuit Breaker and Thermostat
- K Space Heater, 120V Externally Powered with Circuit Breaker and Humidistat
- L Space Heater, 240V Externally Powered with Circuit Breaker
- M Space Heater, 240V Externally Powered with Circuit Breaker and Thermostat
- N Space Heater, 240V Externally Powered with Circuit Breaker and Humidistat

¹ Power source supplied by others

PRESSURE TRANSDUCERS

- B Wetted Parts Including Pressure Sensor, 600 PSI (42 Bar), Fresh Water
- C Wetted Parts Including Pressure Sensor, 300 PSI (21 Bar), Sea Water
- D Wetted Parts Including Pressure Sensor, 600 PSI (42 Bar), Sea Water

MISCELLANEOUS

- AC Alarm Output Contacts, Pump Operating (2 Sets)
- AG Alarm, Audible/Visible, Reservoir Low
- AM Alarm Output Contacts, Fail To Start
- AST Input Terminals, Automatic Start
- AW Alarm Output Contacts, Reservoir Low (Requires option -AG)
- BW Alarm Output Contacts, Phase Failure/Phase Reversal
- BY Alarm Output Contacts, Pump Overload
- CPL Alarm Output Contacts, Overpressure
- EF Alarm Output Contacts, Main Switch Not In Auto (1 Set)
- HV Alarm, Audible
- IEC Marking, CE With External Wet Parts
- IECI Marking, CE With Internal Wet Parts
- KH Alarm Output Contacts, Common Alarm
- NZ Input Terminals, Shutdown Interlock
- OSP Marking, OSHPD Seismic Certification (State of California)(Requires option -SEI)
- PE Alarm Output Contacts, Low System Pressure (Pump On Demand)
- S Tropicalization
- SEI Marking, Seismic Certified
- ZPA Scheduled Service Message
- ZPJ Data Port, Serial Modbus RTU Over 2-Wire or 4-Wire RS485

*Export Packaging available for additional cost

NOTE: For requirements not listed here, please contact your Firetrol representative or the factory.

Firetrol, Inc.

3412 Apex Peakway
Apex, North Carolina 27502
P +1 919 460 5200
F +1 919 460 5250
www.firetrol.com

While every precaution has been taken to ensure accuracy and completeness herein, Firetrol, Inc. assumes no responsibility, and disclaims all liability, for damages result-
ing from use of this information or for any errors or omissions. Specifications and drawings are subject to change without notice. ©2019 Firetrol, Inc., All Rights Reserved.

Publication SD556E-01 Rev. E

Dimensions and Shipping Weight



FTA556E

Jockey_{XG} Pump Controllers - Wye-Delta Open Transition Starting

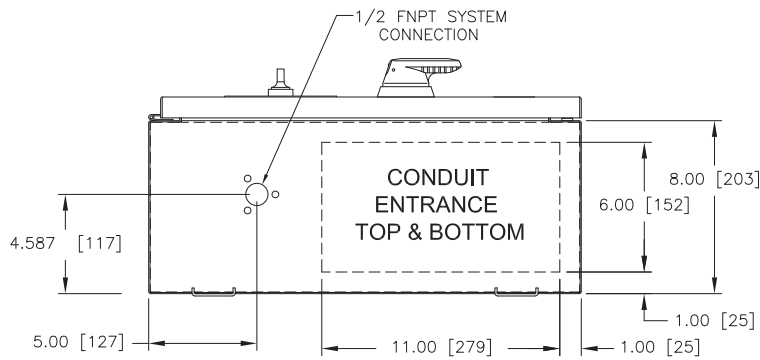
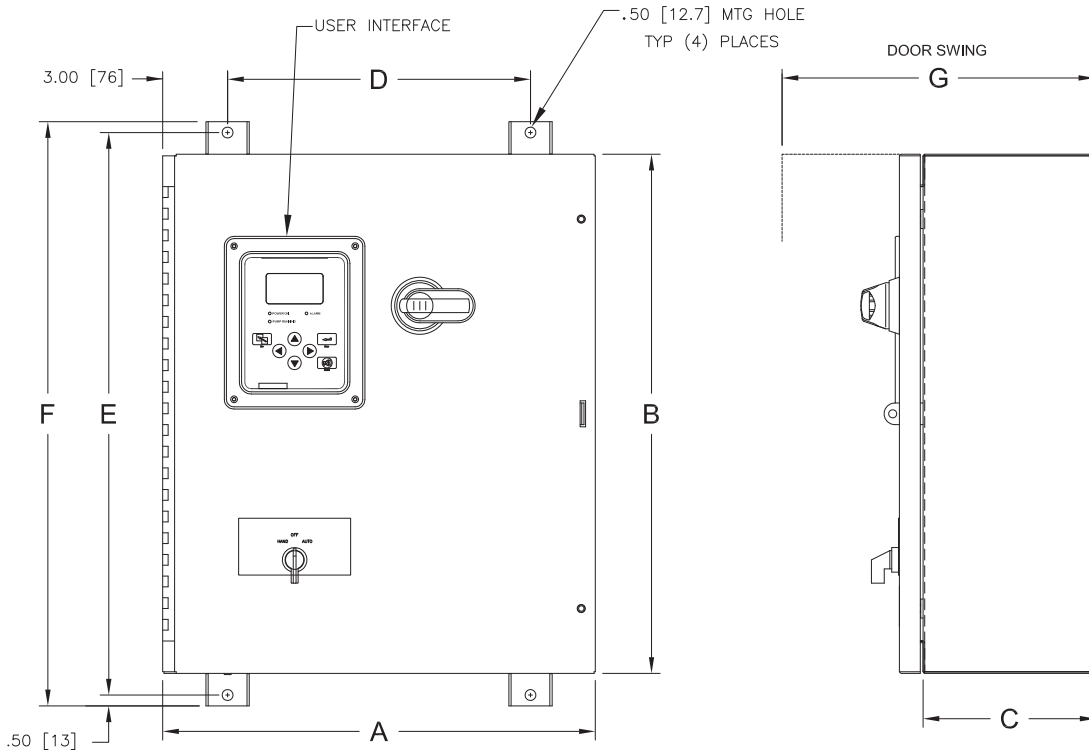

MAXIMUM HORSEPOWER					DIMENSIONS - INCHES [MILLIMETERS]							APPROX. SHIPPING WEIGHT LBS [KG]
200-208 VOLTS	220-240 VOLTS	380-415 VOLTS	440-480 VOLTS	550-600 VOLTS	A WIDE	B HIGH	C DEEP	D	E	F	G	
20	30	40	50	60	20 [508]	24 [610]	8 [203]	14 [356]	26 [660]	27 [686]	28 [712]	80 [36.2]
40	50	60	75	100	24 [610]	30 [762]	8 [203]	16 [406]	32 [812]	33 [838]	32 [812]	100 [45.5]

<p>THIRD ANGLE PROJECTION</p>	SIZE	A	BY	DATE	UPDATED TITLE BLOCK					A	280596	JMW	TEF	08-28-19
	DRAWN BY	CIR	06-12-13	REVISION DESCRIPTION					REV	ECN NO	BY	APP	DATE	
	FINAL APPROVAL	TEF	06-12-13	DIMENSIONS & SHIPPING WEIGHT					FTA556E		DRAWING NUMBER			
	<p>© Firetrol, Inc. Not for construction. Subject to change without notice.</p>					WYE-DELTA JOCKEY XG PUMP CONTROLLER					DD556-05			
										DWG REV	A	ECN NO	280596	SHEET 1 OF 1

All rights reserved. The drawing and the information contained or depicted herein are the sole property of Firetrol, Inc. Copies are communicated to the recipient in strict confidence and may not be retransmitted, published, reproduced, copied or used in any manner, including as the basis for the manufacture or sale of any products, without the express prior written consent of Firetrol, Inc.

Jockey_{XG} Pump Controllers - Wye-Delta Open Transition Starting with C.B.

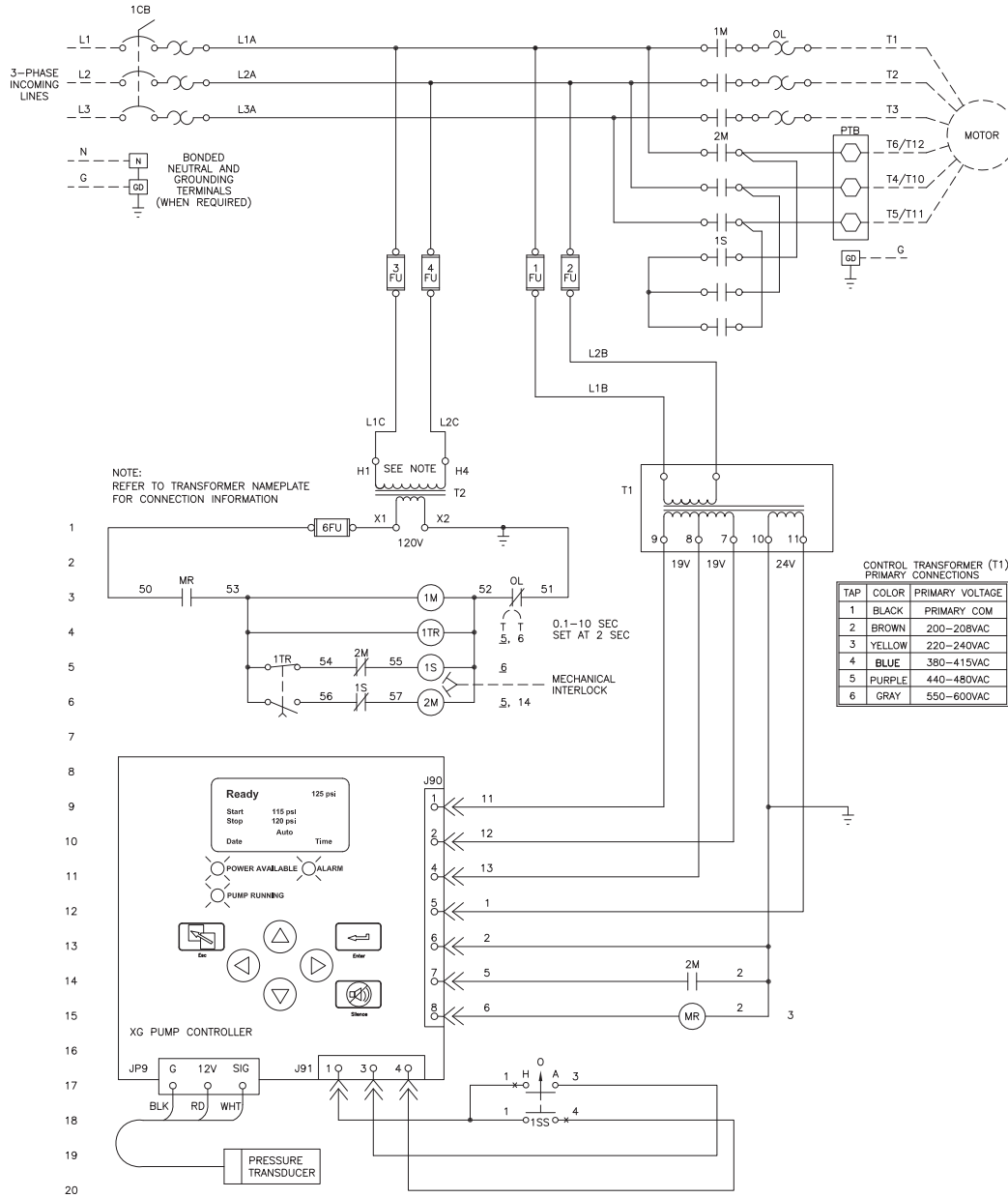

NOTE:
REFER TO TRANSFORMER NAMEPLATE
FOR CONNECTION INFORMATION

TAP	COLOR	PRIMARY VOLTAGE
1	BLACK	PRIMARY COM
2	BROWN	200-208VAC
3	YELLOW	220-240VAC
4	BLUE	380-415VAC
5	PURPLE	440-480VAC
6	GRAY	550-600VAC

LINE TERMINALS—WIRE CAPACITY AND QUANTITY (CU) ①

MAXIMUM MOTOR HORSEPOWER					WIRE SIZE (CU) PER PHASE	WIRE SIZE (CU) NEUTRAL AND GROUND TERMINALS
200-208V	220-240V	380-415V	440-480V	550-600V		
15	15	25	30	50	(1) #14 AWG-#1/0 AWG (1) 2.5 MM ² -50 MM ²	(1) #14 AWG-#8 AWG (1) 2.5 MM ² -16 MM ²
25	30	40	50	-	(1) #14 AWG-#1/0 AWG (1) 2.5 MM ² -50 MM ²	(1) #14 AWG-#1/0 AWG (1) 2.5 MM ² -50 MM ²

MOTOR TERMINALS—WIRE CAPACITY AND QUANTITY (CU) ①

MAXIMUM MOTOR HORSEPOWER					WIRE SIZE (CU) PER PHASE (OL)	WIRE SIZE (CU) PER PHASE (PTB)
200-208V	220-240V	380-415V	440-480V	550-600V		
15	15	30	40	50	(1) #14 AWG-#8 AWG (1) 2.5 MM ² -10 MM ²	(1) #14 AWG-#8 AWG (1) 2.5 MM ² -10 MM ²
30	30	50	50	-	(1) #8 AWG-#1 AWG (1) 10 MM ² -35 MM ²	(1) #8 AWG-#2/0 AWG (1) 10 MM ² -70 MM ²

① FOR CORRECT WIRE SIZING, REFER TO NATIONAL ELECTRICAL CODE, NFPA 70.

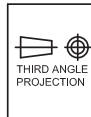
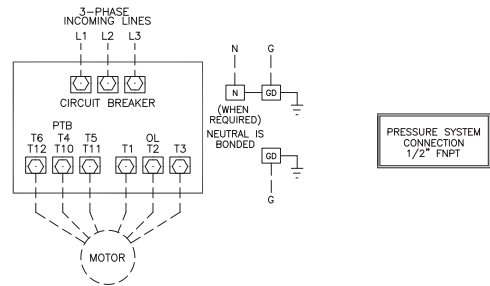

SIZE	A	BY	GFD	DATE	06-05-13
DRAWN BY	GFD	DATE	06-05-13		
FINAL APPROVAL	GFD	DATE	06-05-13		

Firetrol, Inc.
© Firetrol, Inc. Not for construction. Subject to change without notice.

WIRING SCHEMATIC	A	280596	JMW	TEF	08-28-19
REVISION DESCRIPTION	REV	ECN NO	BY	APP	DATE
WIRING SCHEMATIC		FTA556E			
WYE-DELTA JOCKEY XG PUMP CONTROLLER WITH CIRCUIT BREAKER	DRAWING NUMBER WS556-05				
DWG REV	A	ECN NO	280596	SHEET 1 OF 1	

All rights reserved. The drawing and the information contained or depicted herein are the sole property of Firetrol, Inc. Copies are communicated to the recipient in strict confidence and may not be retransmitted, published, reproduced, copied or used in any manner, including as the basis for the manufacture or sale of any products, without the express prior written consent of Firetrol, Inc.

Jockey_{XG} Pump Controllers - Wye-Delta Open Transition Starting with C.B.

- MODIFICATION H - SPACE HEATER, 110-120VAC
- MODIFICATION L - SPACE HEATER, 220-240VAC

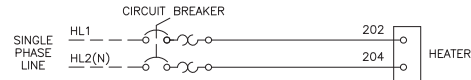

- MODIFICATION J - SPACE HEATER, 110-120VAC (WITH THERMOSTAT)
- MODIFICATION M - SPACE HEATER, 220-240VAC (WITH THERMOSTAT)

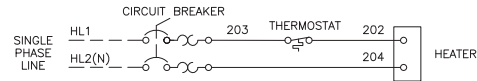

- MODIFICATION K - SPACE HEATER, 110-120VAC (WITH HUMIDISTAT)
- MODIFICATION N - SPACE HEATER, 220-240VAC (WITH HUMIDISTAT)

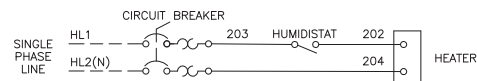

- MODIFICATION AC - PUMP OPERATING ALARM CONTACTS

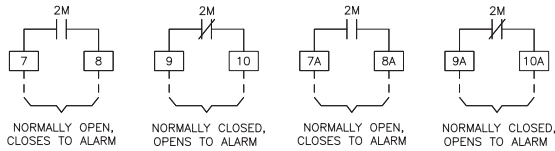

- MODIFICATION BY - PUMP OVERLOAD REMOTE ALARM CONTACT

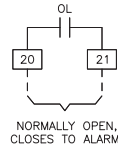

- MODIFICATION NZ - INTERLOCK SHUTDOWN IN AUTO

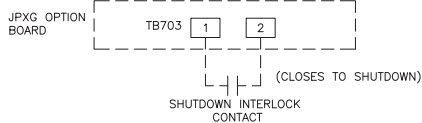

- MODIFICATION AST - REMOTE AUTO START INPUT

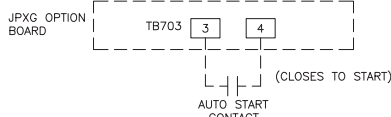

WIRING REQUIRED WHEN JPXG OPTION BOARD IS USED

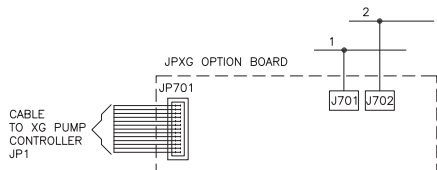

NOTE:
TERMINAL NUMBERS SUBJECT TO CHANGE

- MODIFICATION AM - PUMP FAILED TO START REMOTE ALARM CONTACTS

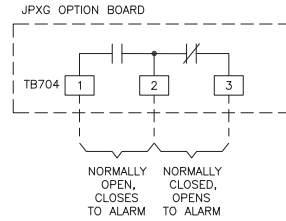

- MODIFICATION EF - SWITCH NOT IN AUTO REMOTE ALARM CONTACTS

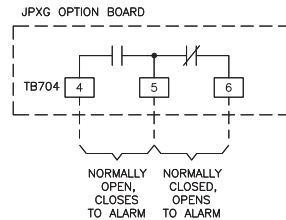

- MODIFICATION KH - COMMON TROUBLE REMOTE ALARM CONTACTS

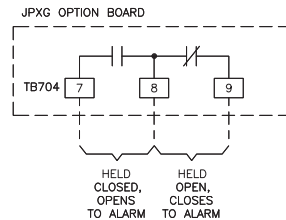

- MODIFICATION BW - PHASE FAILURE/REVERSAL REMOTE ALARM CONTACTS

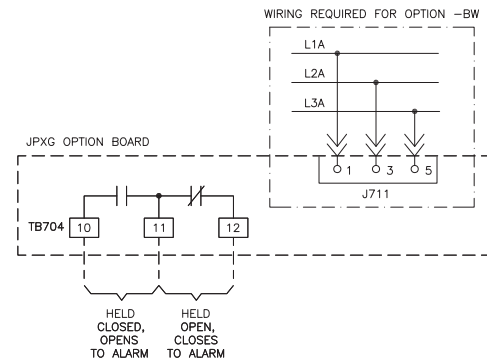

CONTROL AND ALARM TERMINAL WIRE CAPACITY	
JPXG OPTION BOARD TERMINALS	#18-12 AWG [0.75-4 MM ²]
PUMP OPERATING TERMINALS	#14-12 AWG [2.5-4 MM ²]
CIRCUIT BREAKERS	#14-4 AWG [2.5-25 MM ²]

	SIZE	A	BY	TEF	DATE	06-05-13	<p>© Firetrol, Inc. Not for construction. Subject to change without notice.</p>	UPDATED TITLE BLOCK	A	280596	JMW	TEF	08-28-19
	DRAWN BY	TEF	FINAL APPROVAL	TEF	06-05-13	REVISION DESCRIPTION		FTA556E	REV	ECN NO	BY	APP	DATE
	WIRING SCHEMATIC		FTA556E		DRAWING NUMBER			WS556-06					
	WYE-DELTA JOCKEY XG PUMP CONTROLLER OPTIONS AND MODIFICATIONS		DWG REV	A	ECN NO	280596		SHEET 1 OF 1					

All rights reserved. The drawing and the information contained or depicted herein are the sole property of Firetrol, Inc. Copies are communicated to the recipient in strict confidence and may not be retransmitted, published, reproduced, copied or used in any manner, including as the basis for the manufacture or sale of any products, without the express prior written consent of Firetrol, Inc.