

MYERS® S50HT SERIES

The Myers S50HT series high-flow pump is designed for dependability in demanding environments. All cast iron construction and special features to protect the motor make this a pump for the long haul. The S50HT in a boiler blow-down application can withstand liquid temperatures up to 200°F. The non-clogging, semi-open impeller ensures unimpeded flow for high-capacity sump operation.



PW217-280 Control Panel Required (sold separately)

APPLICATIONS

High-capacity sump, effluent, boiler blow-down

SPECIFICATIONS

Capacities – 100 GPM (378 LPM)
Shut-off Head – 50' (15.2 m)
Max. Spherical Solids – 3/4" (19 mm)
Liquids Handling – Domestic effluent and drain water
Max. Liquid Temperature – 200°F (93°C)
Motor/Electrical Data – 1/2 HP, 3450 RPM, PSC with thermal overload, 115V, 12 FLA, 1Ø, 60Hz
Acceptable pH Range – 5-9
Specific Gravity – .9-1.1
Viscosity – 28-35 SSU
Discharge, NPT – 2" (50 mm)
Housing – Cast iron
Minimum Sump Diameter – Simplex: 24" (61 cm)
 Duplex: 36" (91.4 cm)
Power Cord – 20', 16/4, SOOW, SOOW-A
Shaft Seal – Durable silicon carbide
Float Switch On/Off – On – 17.8" (452)
 Off – 8.8" (224)

FEATURES

Tough Against Corrosion

Cast iron housing, volute case and impeller resist the most extreme environments

Stainless Steel Protection

Stainless steel motor shaft, impeller lock nut and external hardware

Built-in Overload Protection

Heat sensor overload protection with automatic reset when motor cools to a safe operating temperature

Smooth Running

Semi-open impeller is designed to resist clogging

Cool-running

Oil-filled motor provides continuous bearing lubrication and maximizes heat dissipation

Extended Service

Fully lubricated ball bearings and shaft seal for longer service life

High-flow Discharge

2" (50 mm) NPT discharge

Height Adjustable

Legs are drilled and tapped with 1/2" NPT threads to allow pump height adjustment

ORDERING INFORMATION

Catalog Number	HP	Volts	Phase/Cycles	Amps	Discharge Size	Switch Type	Cord Length	Approx. Wt. Lbs.
S50HTPC1	1/2	115	1/60	12	2"	Tethered Automatic*	20'	64
PW217-280	S50HT control box							

*Control box is required for operation. Not included with pump - order separately.

MYERS® S50HT SERIES

DIMENSIONS

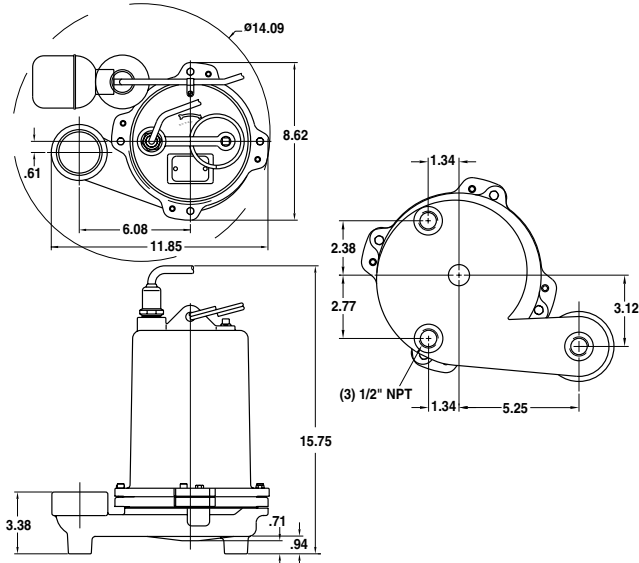

PUMP PERFORMANCE

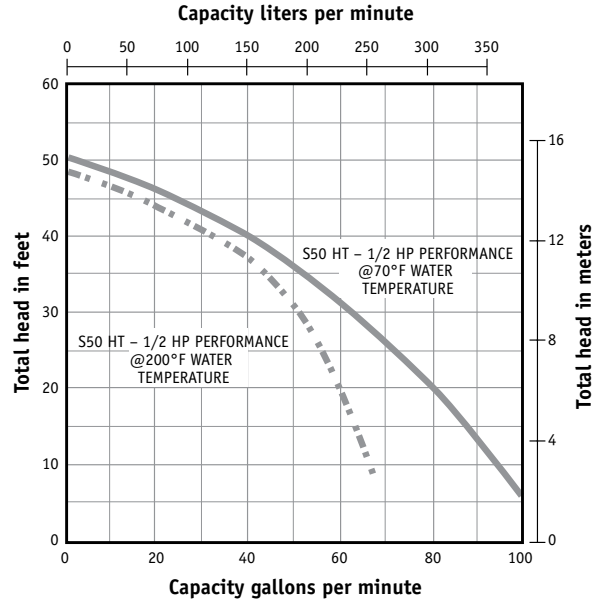

USA
293 WRIGHT STREET, DELAVAN, WI 53115 WWW.FEMYERS.COM
PH: 888-987-8677 ORDERS FAX: 800-426-9446

CANADA
490 PINEBUSH ROAD, UNIT 4, CAMBRIDGE, ONTARIO N1T 0A5
PH: 800-363-7867 ORDERS FAX: 888-606-5484

Because we are continuously improving our products and services, Pentair reserves the right to change specifications without prior notice.